

Variable displacement vane pump (with mechanical pressure compensator)

PLP-Type

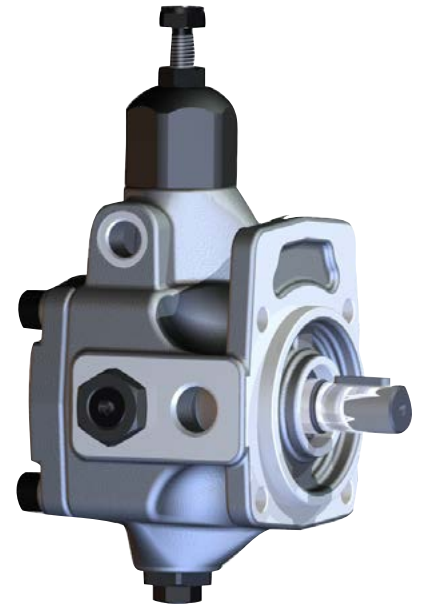

Key Features:

- Rotation:** Right (viewed from shaft end)
Mounting flanges: 4-hole flange (UNI ISO 3019/2) and Rectangular Flange as gear pump Size 2
Connections: GAS BSP (UNI ISO 228/1)
Integrated mechanical displacement limiter as standard on all pumps
Set-up for combined pumps on request

Series/Name	Rated Displacement (cm ³ /r [in ³ /r])	Maximum Flow Capacity at 1450 rpm (L/min) [US gpm]	Maximum Pressure (bar) [psi]
01-PLP-05-16	from 4 [0.24] to 16 [0.98]	from 6 [1.59] to 23 [6.08]	120 [1740]

CONTENTS

GENERAL DESCRIPTION A-3

TECHNICAL DATA A-4

ORDERING CODE A-5

CHARACTERISTIC CURVES..... A-6

DIMENSIONS A-7

COMBINED PUMPS..... A-8

INSTRUCTIONS FOR INSTALLATION AND USE A-11

SETTINGS A-13

WARNING

All Berarma pumps have been carefully checked during manufacture and subjected to stringent testing cycles before shipment. To achieve optimum performance, avoid problems and maintain the warranty, the installation instructions enclosed with each pump must be strictly observed.

NOTES

Before selection or use of any Berarma product, it is important that the purchaser analyses all aspects of its application and reviews the information in the current Berarma Technical-Sales catalogues. Due to the many different operating conditions and applications for Berarma products, the purchaser, through their own analysis and testing, solely responsible for making the final selection of the products and assuring that all performance and safety requirements are met.

Berarma S.r.l. accepts no responsibility for any editing mistakes in this catalogue.
Berarma S.r.l. reserves the right to modify these data without prior notice.

GENERAL DESCRIPTION

As a result of the constant research carried out in order to introduce innovative products to the market characterised by high technological content and reliability, BERARMA has launched the **new 01 PLP series of LOW PRESSURE variable displacement vane pumps equipped with a MECHANICAL pressure regulating device.**

The new series of 01 PLP pumps, like all other BERARMA variable displacement vane pumps, ensure

- SILENT RUNNING
- HIGH EFFICIENCY
- LONG WORKING LIFE
- MODULAR DESIGN
- ENERGY SAVING

Moreover, the innovation related to the new series of vane pumps has led to an **IMPROVEMENT OF DISPLACEMENT CONTROL DYNAMICS and IMPROVED AXIAL BALANCING** thanks to the refinement of the hydrostatic compensation of the distribution plates.

The new series of 01 PLP pumps is supplied with:

- ISO standard MOUNTING FLANGES
- GAS BSP standard PORT CONNECTIONS
- flow regulator unit in order to mechanically reduce pump displacement
- MECHANICAL pressure regulating device
- (on request only) set-up for coupling to all BERARMA pumps or to the main others types of pump available on the fluid power market.

Based on the above features, the new series of 01 PLP pumps is of great interest to the market.

What makes the new BERARMA 01 PLP series pumps interesting for the market?

- INNOVATIVE SHAPES AND DESIGN
- COMPACT OVERALL DIMENSIONS
- 120 bar [1740 psi] working pressure
- REDUCTION IN WEAR on internal pump cartridge parts

NOTES AND DEFINITION OF PUMP COMPONENTS

Body (1); Drive rotor (2) where the Vanes (3) flow; Stator (mobile ring with varying eccentricity and consequently displacement) (4); Side distribution plates (5); Guide block balancing adjustment screw (6) (**absolutely must not be tampered with by the user**); Displacement adjustment piston (7); Flow regulator unit (8); Mechanical pressure regulating device (9).

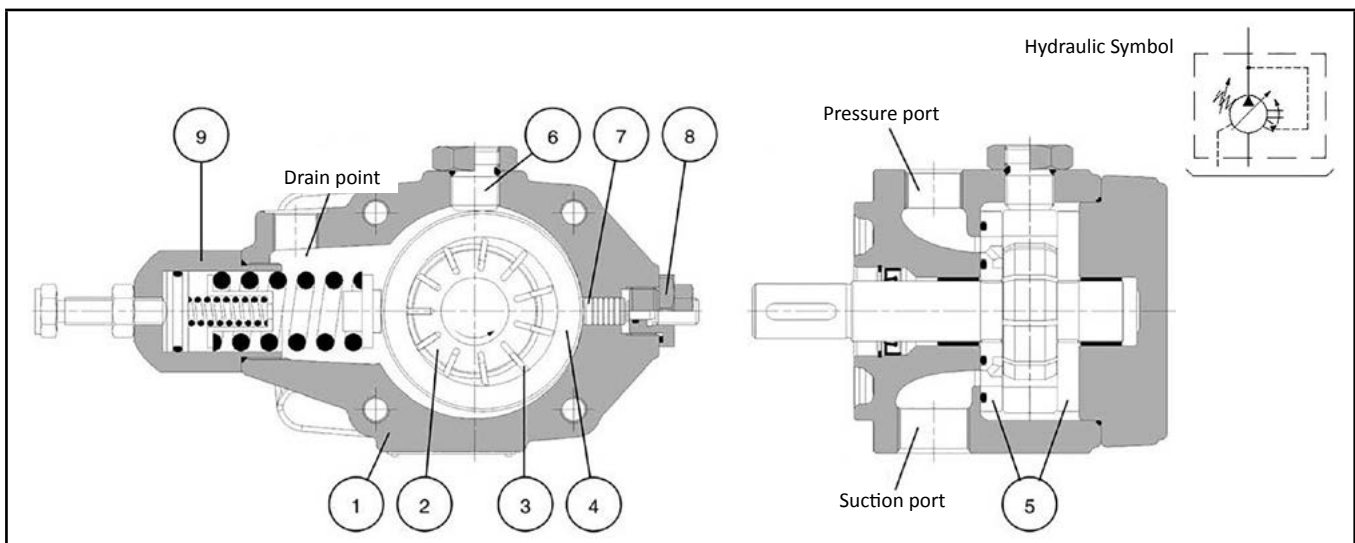

TECHNICAL DATA

NOMINAL SIZE		SIZE 05
Geometric displacement according to UNI-ISO 3662 (cm³/r) [in³/r]		16 [0,976]
Actual displacement (cm³/r) [in³/r]		17.9 [1,092]
Due to manufacturing tolerances, the value can vary by approx. ±3%		
Maximum working pressure (bar) [psi]		120 [1740]
Pressure peak exceeding 30% of the maximum operating pressure must be eliminated by adopting the appropriate measures		
Control pressure setting (bar) [psi]		H: 20 ÷ 120 [290 ÷ 1740]
Mounting flange and port connections		F - Flange 4 bolt (UNI ISO 3019/2) GAS BSP (UNI ISO 228/ 1) threads FGR2 - Flange as gear pump SIZE 2 GAS BSP (UNI ISO 228/1) threads
Permitted maximum drain port pressure (bar) [psi]		1 [14.5]
Inlet pressure (bar) [psi]		0.8 ÷ 1.5 [11.6 ÷ 21.8] absolute
Speed range (rpm)		800 ÷ 1800
Rotation direction (viewed from shaft end)		R - Right (clockwise)
Loads on drive shaft		NO RADIAL OR AXIAL LOADS ALLOWED
Maximum torque on primary shaft (Nm) [lb in]	T _{max}	F flange 110 [973] FGR2 flange 70 [619]
Hydraulic fluid		HM hydraulic oil according to ISO 6743/4 ; HLP hydraulic oil according to DIN 5124/2 for other fluids contact Berarma Technical-Sales Service
Viscosity range (cSt, mm²/s)		22 - 68 at operating temperature
Starting viscosity under full flow conditions (cSt, mm²/s)		400 max
Viscosity index according to ISO 2909		100 min
Inlet fluid temperature range (°C) [°F]		+15 / +60 [14 / 140]- pay attention to viscosity range
Maximum acceptable fluid contamination level		20/18/15 according to ISO 4406/99 CLASS 9 according to NAS 1638
Recommended fluid contamination level for a longer pump working life		18/ 16/ 13 according to ISO 4406/99 CLASS 7 according to NAS 1638
Moment of inertia (kgm²)		0.00012
Pump weight (kg) [lb]		
01 PLP 05-16 FHRM		7.4 [16.3]
01 PLP 05-16 FHRMA		7.6 [16.8]
01 PLP 05-16 FGR2HRM		7.3 [16.1]
For further information and/or different operating conditions, please contact Berarma Technical-Sales Service		

ORDERING CODE

SERIES	NAME	SIZE	DISPLACEMENT	FLANGE	PRESSURE SETTING	ROTATION	SEALS	COMBINED PUMPS
01	PLP	05	16	F	H	R	M	A

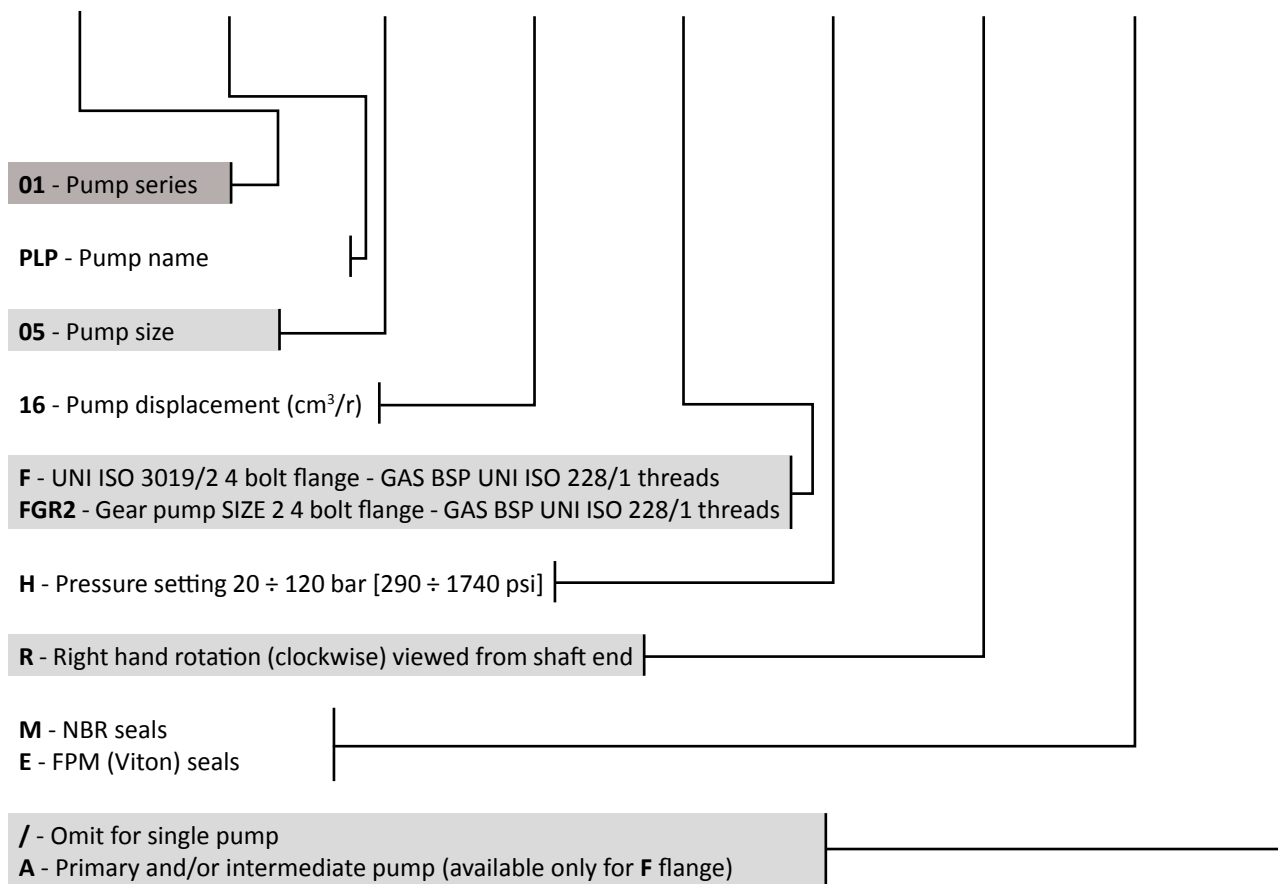

Ordering code example:

- 01 PLP 05-16 FHRM
- 01 PLP 05-16 FHRMA
- 01 PLP 05-16 FGR2HRM

ORDERING CODE

CHARACTERISTIC CURVES

Indicative values measured on Berarma test machine, referring to 1500 rpm, with HM hydraulic oil according to ISO 6743/4, ISO VG 32 according to ISO 3448, temperature 48 °C [118 °F].

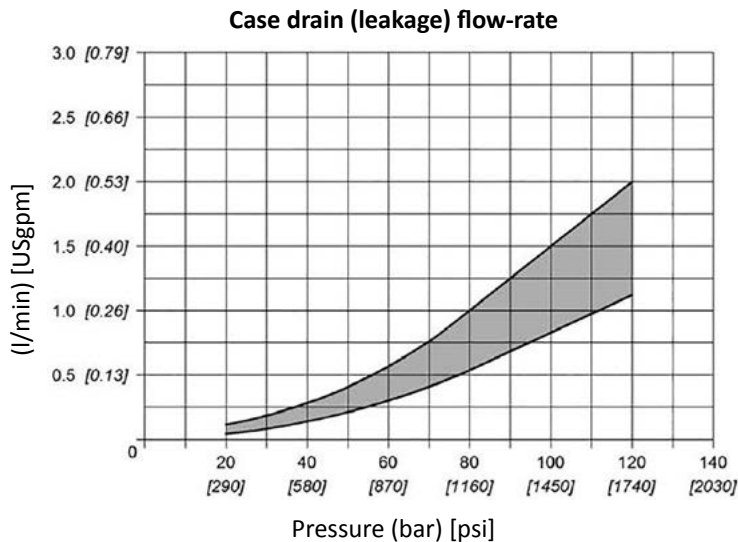
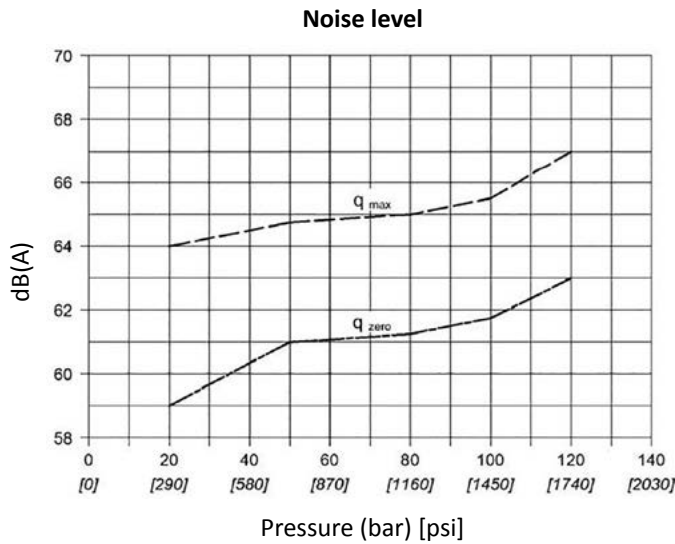
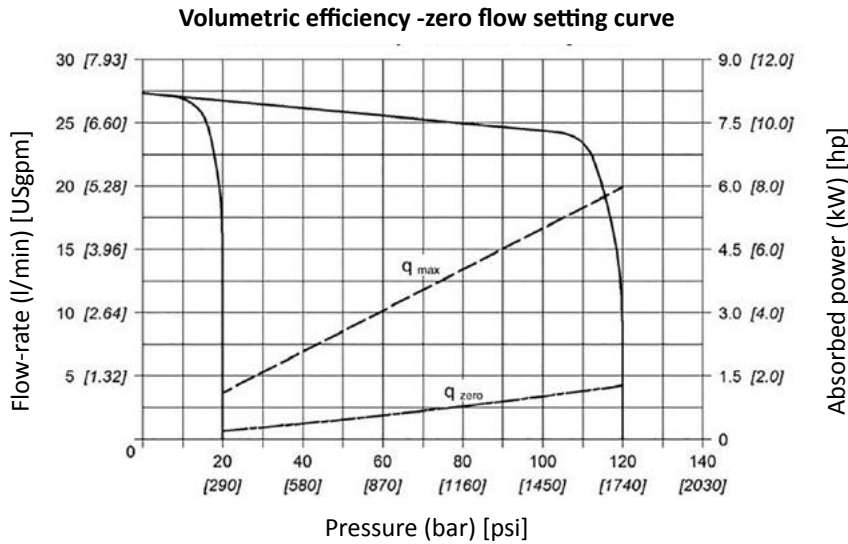

Absorbed power (kW) [hp]

Indicative maximum noise level values measured with sound-level meter placed one metre [39.370"] from the pump, with flexible coupling

Pump under zero flow setting conditions

DIMENSIONS

01 PLP 05 16 FHRM

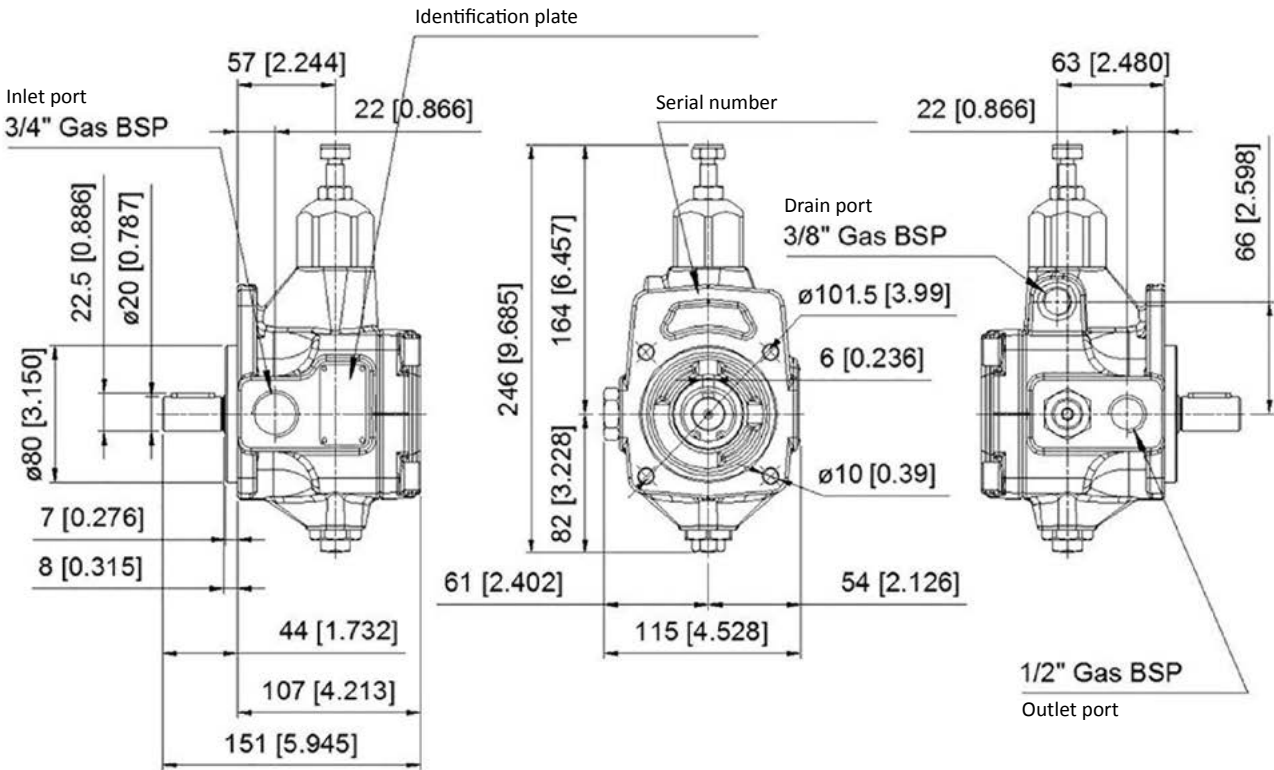

Dimensions inside [] are in inches

THRU-DRIVE SHAFT (-A)

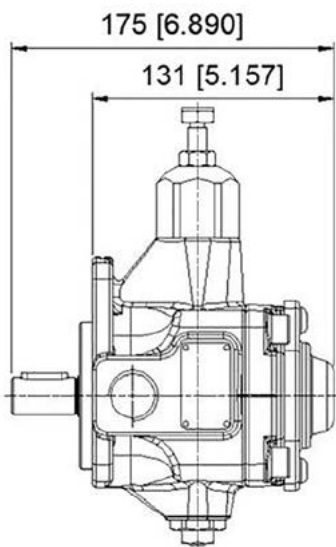

FLANGE AND SHAFT FGR2

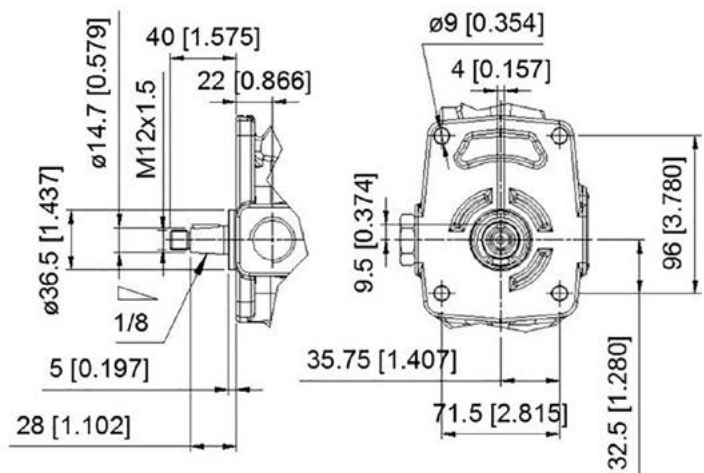

Dimensions inside [] are in inches

NOTE: Available only with F flange

For combined pump solutions, please see pages 8÷10

Dimensions inside [] are in inches

COMBINED PUMPS

On request, BERARMA pumps from the 01 PLP series can be set up for coupling:

- to pumps belonging to the same 01 PLP series;
- to pumps belonging to other BERARMA series (PVS, PSP, PSPK, PHV);
- to the main others types of pumps available on the fluid power market.

The 01 PLP series pumps set up for coupling are marked by the letter "A" in the ordering code. In these pumps, the shaft and the rear pump cover are set up for coupling to the various available coupling units.

- Unscrew the screws marked (1) from the primary pump (screws will not be re-installed)
- Remove the pump cover marked as (2) from the primary pump (cover will not be re-installed)
- Mount the coupling unit paying attention to the seals (Note: primary pump drainage fluid will fill up the coupling bell-housing)
- Mount the secondary pump

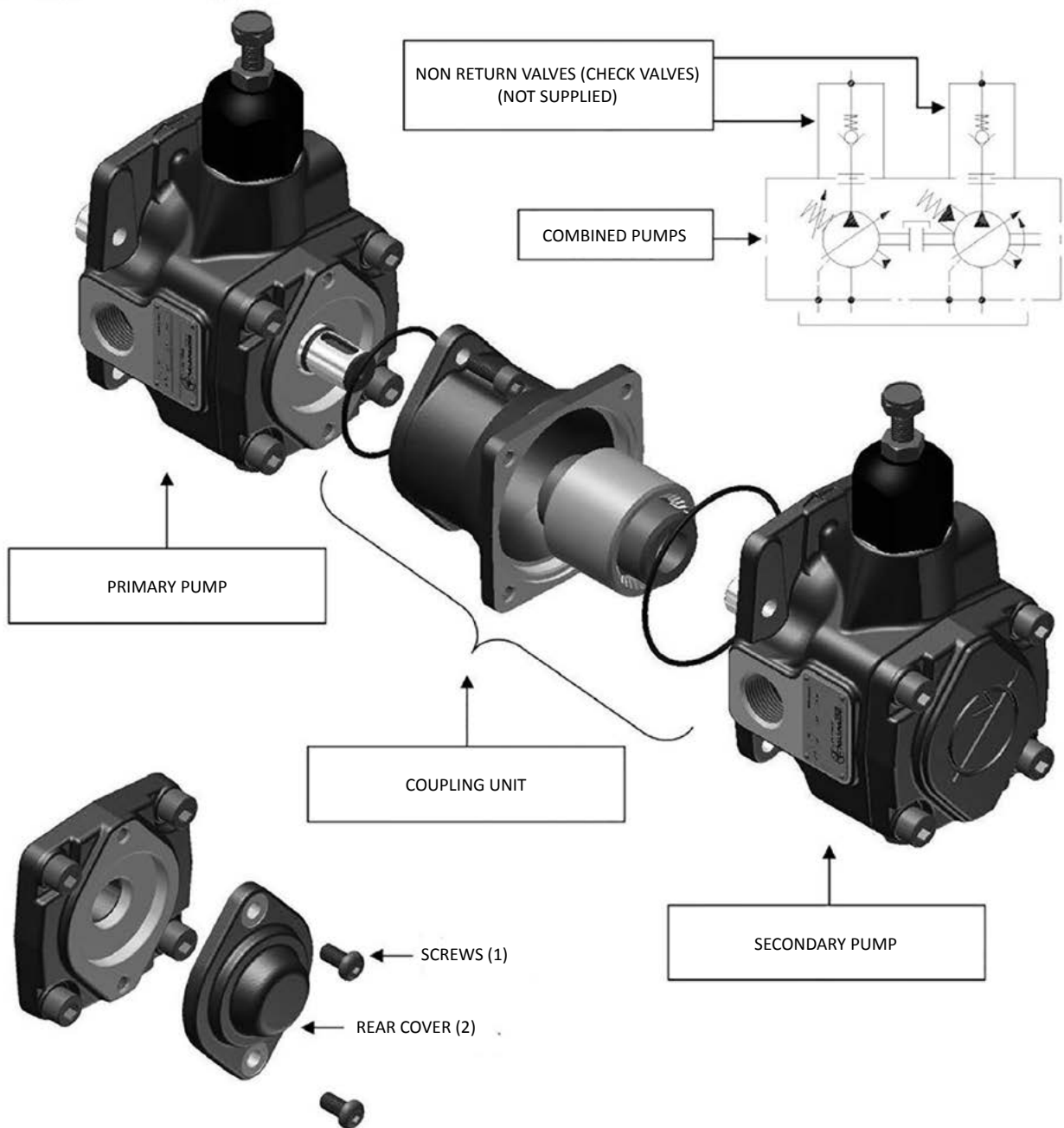

Combined pumps should be mounted in decreasing order of absorbed power, paying attention to the maximum acceptable torques (see diagram below).

The ordering code for a combined pump should be specified according to coupling sequence (primary pump code + coupling unit code + secondary pump code).

- The sum of individual torques of all pumps in the complete pump combination must not exceed the maximum permissible torque value applicable to the primary pump shaft (T_{max} see page 5).
- Secondary pump torque (or sum of torques for more than one secondary pump) must not exceed the coupling unit maximum thru drive torque (T_a , see table below).

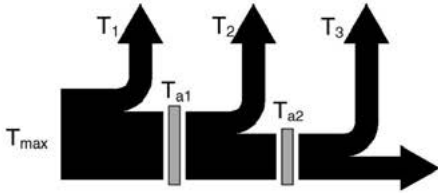

$$\begin{cases} T_1 + T_2 + T_3 < T_{max} \\ T_2 + T_3 < T_{a1} \\ T_3 < T_{a2} \end{cases}$$

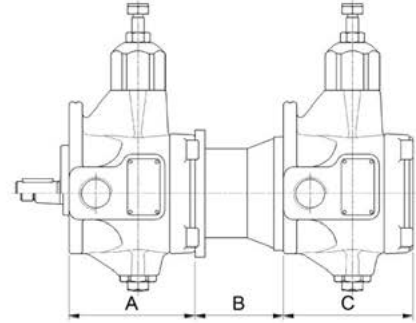

PRIMARY PUMP		SECONDARY PUMP		COUPLING UNIT		
Pump type	A	Pump type	C	Code	B	Maximum thru drive torque T_a
01 PLP05 16 FHRM A	104 [4,094]	01 PLP 05 F	107 [4,213]	3000010200	73 [2,874]	55 Nm [487 lb in]
		01 PLP 05 FGR2	107 [4,213]	3000011200	72 [2,835]	
		01 PHV 05 F	145 [5,709]	3000010200	73 [2,874]	
		01 PHV 05 FGR2	145 [5,709]	3000011200	72 [2,835]	
		02 PVS -PSP - PSPK - 1 F	159 [6,260]	3000010100	75 [2,953]	
		SAE "A"	n	3100000100	88.5 [3,484]	
		INGR. 1P	(..)	3000011000	64 [2,520]	
		INGR. 1	(**)	3000011100	64 [2,520]	
01 PHV 05 ... A	139 [5,472]	01 PLP 05 F	107 [4,213]	3000010200	73 [2,874]	110 Nm [974 lb in]
		01 PLP 05 FGR2	107 [4,213]	3000011200	72 [2,835]	
PVS - PSP - PSPK Size 1	132 [5.197]	01 PLP 05 F	107 [4,213]	3000010200	73 [2,874]	110 Nm [974 lb in]
		01 PLP 05 FGR2	107 [4,213]	3000011200	72 [2,835]	
01 PHV 1 ... A	173 [6,811]	01 PLP 05 F	107 [4,213]	3000020400	85 [3,346]	110 Nm [974 lb in]
		01 PLP 05 FGR2	107 [4,213]	3000022200	90 [3,543]	
PVS - PSP - PSPK Size 2	173 [6,811]	01 PLP 05 F	107 [4,213]	3000020400	85 [3,346]	110 Nm [974 lb in]
		01 PLP 05 FGR2	107 [4,213]	3000022200	90 [3,543]	
PVS - PSP - PSPK Size 3	198 [7.795]	01 PLP 05 F	107 [4,213]	3000020400	85 [3,346]	110 Nm [974 lb in]
		01 PLP 05 FGR2	107 [4,213]	3000022200	90 [3,543]	

(*) For the secondary pump SAE A flange dimensions please see page 10.
In order to find out the secondary SAE flange pump axial dimension please see the manufacturer's catalogue.

(**) For the secondary gear pump flange dimensions please see page 10.
In order find out the secondary gear pump axial dimension please see the manufacturer's catalogue.

For other coupling unit types, please contact Berarma Technical-Sales Service.

Dimensions inside [] are in inches

SAE FLANGE DIMENSIONS FOR BERARMA COUPLING KIT

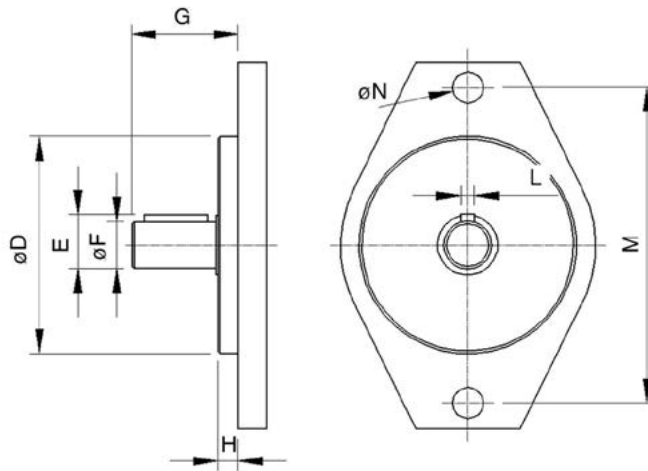

Secondary pump	Secondary pump with SAE "A" 2-bolt mounting flange should conform to the dimensions below								
	Ø D	E	Ø F	G		H	L	M	Ø N
SAE "A"	Ø82.5 [3.248]	21.1 [0.831]	Ø19.05 [0.750]	min	max	7 [0.276]	4.8 [0.189]	106.4 [4.189]	11.1 [0.438]
				32 [1.260]	59 [2.323]				

GEAR PUMP FLANGE DIMENSIONS FOR BERARMA COUPLING KIT

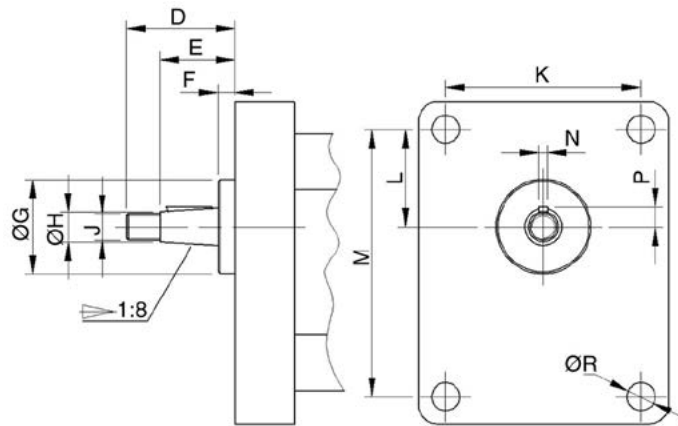

Secondary pump	The secondary gear pumps should conform to the dimensions below											
	D	E	F	Ø G	Ø H	J	K	L	M	N	P	Ø R
gear pump 1P	29 [1.142]	20 [0.787]	4 [0.157]	25.4 [1.000]	8 [0.315]	M7	52.4 [2.063]	26.2 [1.031]	71.9 [2.831]	2.4 [0.094]	5.3 [0.209]	7.5 [0.295]
gear pump 1	35 [1.378]	23.5 [0.925]	5.5 [0.217]	30 [1.181]	12 [0.472]	M10x1	56 [2.205]	24.5 [0.965]	73 [2.874]	3 [0.118]	7.9 [0.311]	6.5 [0.256]
gear pump 2	40 [1.575]	28 [1.102]	5 [0.197]	36.5 [1.437]	14.7 [0.579]	M12x1.5	71.5 [2.815]	32.5 [1.280]	96 [3.780]	4 (*) [0.157]	9.7 [0.382]	8.5 [0.335]

(*) It is also possible to couple size 2 gear pumps with an "M" dimension of 3.2 [0.126].

Dimensions inside [] are in inches

INSTRUCTIONS FOR INSTALLATION AND USE

SIZE 05 pumps from the 01 PLP series can be mounted in any position.

When the pump is installed over the reservoir fluid level, pay attention to the inlet pressure (see page 4).

Cleanliness is essential during assembly!

Motor-pump coupling must be made with a self-aligning flexible coupling with convex teeth and a polyamide cam. When assembling make sure that:

- **the distance between the two half-couplings strictly falls within the specified values (see page 12);**
- **the pump shaft and the motor shaft are accurately aligned: concentricity within 0.05 mm [0.002"], angular displacement within 0.2° (see drawing at the bottom of this page);**
- **strictly no radial or axial loads on the pump shaft.**

Other types of motor-pump coupling are not permitted.

The fluid tank must be suitably sized in order to exchange the thermal power generated by the various system components and to provide a low recycle rate (tank capacity approximately 4 times the flow rate per minute of the pump). In systems where the pump runs for a long time under zero flow setting conditions, the installation of a heat exchanger in the drain line is recommended (pay attention to the pressure on the drain port, see page 4).

Maximum operating temperature must not exceed 60 °C [140 °F] under any circumstances.

To ensure the maximum pump working life, the inlet fluid temperature must never be above 50 °C [122 °F].

Suction pipe. The suction pipe should be as short as possible, with a small number of bends and without internal section changes. The minimum section of the inlet pipe must be equal to the section of the thread of the pump inlet port. The pipe-end inside the tank should be cut at 45°, should have a minimum distance from the tank bottom of not less than 50 mm [2"], and there should always be a minimum height of suction of 100 mm [4"]. **The suction pipe should be completely airtight.**

Drain pipe. The drain pipe must always be independent from the other return lines, connected directly to the tank, and extended sufficiently inside the tank so as to be below the minimum fluid level to avoid generating foam and to prevent emptying when the pump is not running. Moreover, the drain pipe must also be at the highest possible position in relation to the pump in order to always prevent fluid emptying from the pump, and must be free of restrictions. **The drain pipe should be as far as possible from the suction pipe to prevent hot fluid being circulated.**

Pressure line. Ensure that the pressure line is strong enough. It is recommended that a non-return valve (check valve) is installed on the pump pressure line as well as an automatic air bleed valve, for trouble free operation.

Ensure that any valves, taps and gate valves on the suction and pressure pipes are fully opened and all protective caps removed. Fill the pump through the case drain port and replace the drain pipework. Check that the reservoir is full of fluid.

Ensure that the pump shaft can be rotated manually without any resistance.

Check that the motor rotation direction is the same as the pump rotation direction: right-hand rotation (clockwise) viewed from shaft end of the pump.

Start the motor (in jogging mode), allowing free circulation of fluid to the tank in order to facilitate priming.

The pump should prime within 5 seconds. If it does not do so, switch off and investigate the cause. The pump should not run empty.

During INITIAL INSTALLATION, the pump must run under maximum flow conditions (P connected to T), with the fluid flowing directly into the tank, without pressure for several minutes. Care should be taken to eliminate all the air from the system during this process.

Subsequent start-ups under zero flow setting conditions are admissible only with pressure not exceeding 30 bar [435 psi], and with the system and pump completely filled with fluid.

If the volume adjustment unit is set to less than 50% of the nominal flow-rate, the pump can only start on condition that the system and the pump are completely filled with fluid.

During the initial and subsequent starting operations, it is necessary that the pump (ambient) and fluid temperature do not differ by more than 20°C [68°F]. If this is the case, the pump should be switched on only for short intervals of approximately 1÷2 seconds (start/stop mode) without pressure, until the temperatures are balanced.

All Berarma products are covered by a **1 YEAR WARRANTY** for manufacturing or material defects effective from the shipment date, but in any case **NO LONGER THAN 18 MONTHS FROM THE PRODUCTION BATCH DATE**. The warranty is for the exclusive benefit of the original purchaser of the products.

For further information, please contact the Berarma Technical-Sales Service.

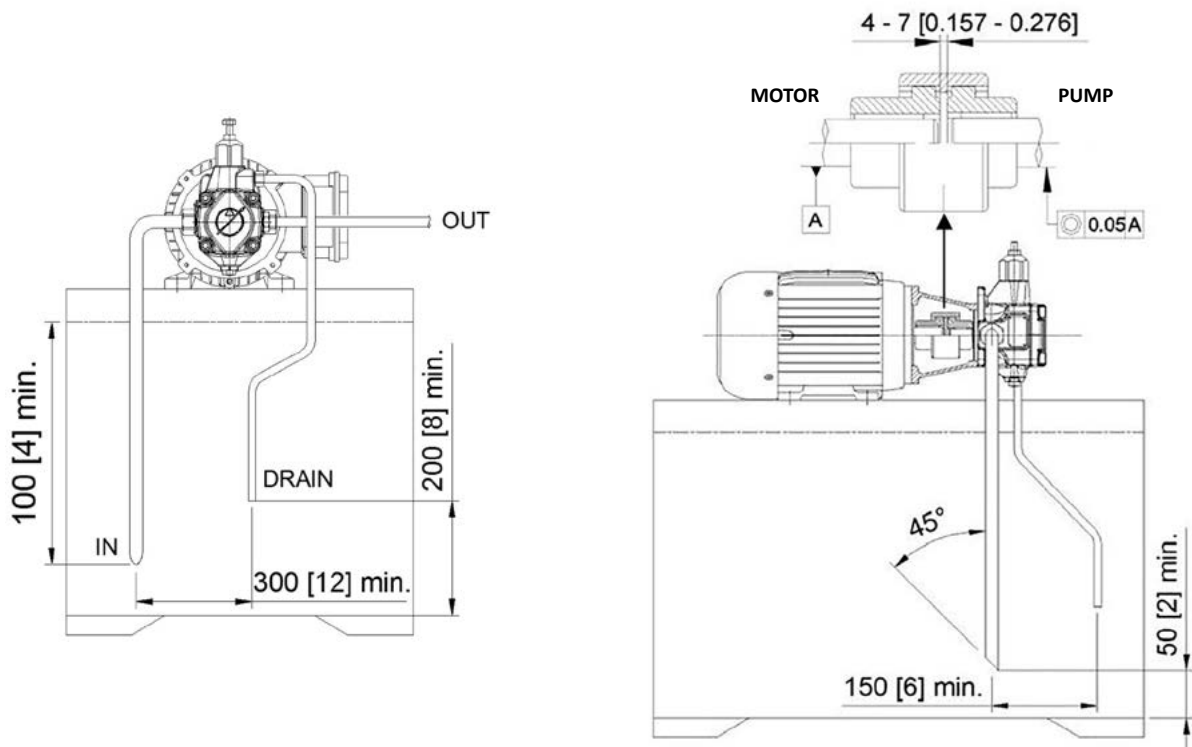

Dimensions inside [] are in inches

SETTINGS

Pressure adjustment

All BERARMA 01 PLP series pumps are equipped with a mechanical pressure adjustment unit. This allows the pump pressure to be set at the zero-flow setting. Clockwise rotation increases pressure (pay attention to avoid going out of the pressure setting range specified on page 4).

Warning: During the first run, make sure that the pressure adjustment screw is tight enough to ensure the correct priming of the pump.

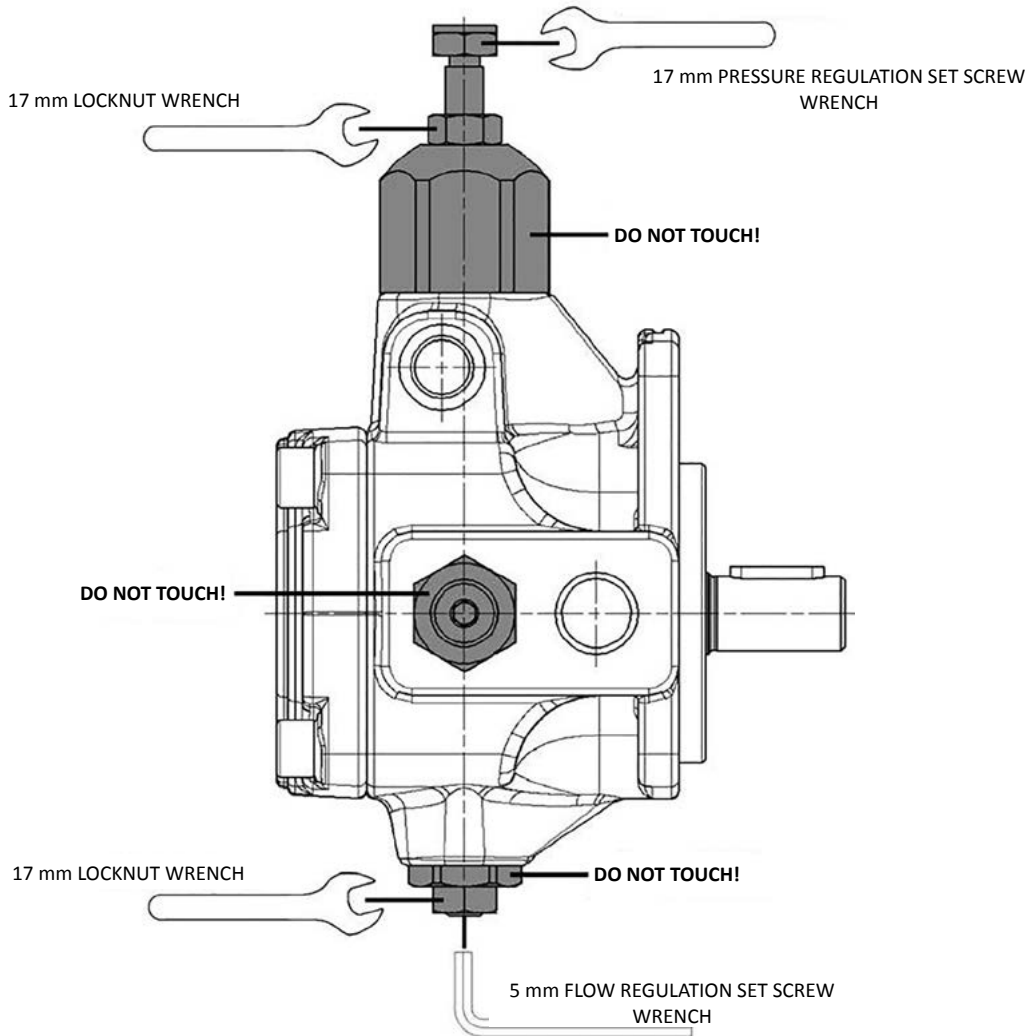

Flow regulator

All BERARMA 01 PLP series pumps are equipped with a flow regulator unit. This allows the mechanical reduction of the pump displacement in relation to the nominal value. Clockwise rotation decreases the pump displacement.

Warning: If the flow regulator unit is set to less than 50% of the nominal displacement, the pump can only start on condition that the system and pump are completely filled with fluid.

Nominal size	Actual displacement	Reduced displacement by screw turn	Minimum achievable displacement
SIZE 05	17.9 cm ³ [1.092 in ³]	9.7 cm ³ [0.592 in ³]	3.1 cm ³ [0.189 in ³]

Indicative values influenced by manufacturing tolerances.